

**ADDENDUM NO. 19**

**Date: 10.13.2025**

**Project:**

**Westfield Washington School Corporation  
Centennial Road Reconstruction  
Bid Package 05  
17707 Centennial Road,  
Westfield, IN. 46074**

**Owner:**

**C/O Westfield Washington School Corporation  
19500 Tomlinson Road  
Westfield, IN 46074**



BUILDING A **BETTER** FUTURE

**Construction Manager:**

Hagerman, Inc  
10315 Allisonville Road  
Fishers, IN 46038

TO: All Interested Bidders of Record

This Addendum #19, Dated 10.13.2025, forms part of the contract documents and modifies the original Bidding Documents Dated 09.15.2025. Please acknowledge receipt of this Addendum in the space provided on the Bid Form. Failure to acknowledge this Addendum may subject the Bidder to disqualification.

The Hagerman, Inc portion of this Addendum consists of the following information:

**I. GENERAL INFORMATION**

1. This is for Addendum #19 Dated 10.13.2025. (Please note this is really Addendum #02 for the Centennial Road Reconstruction Project but is sequentially Addendum #19 on the overall Westfield Washington School New Middle School West Project, so we will refer to it as Addendum #19).
2. The project is out for bid and due to a technical glitch, we are readvertising and extending the bid due date from 10.16.2025 to 11.04.2025 at 11:00AM.

3. Hagerman has revised and reissued the Bid Advertisement, Instructions to Bidders, and Bid Form to reflect the updated Pre-Bid Meeting and Bid Opening date. The new Pre-Bid Meeting will be at 11:00AM, October 22, 2025, at the WWS NMS Jobsite trailer (17707 Centennial Rd, Westfield, IN 46074) and new Bid Opening will be at 11:00AM, November 4, 2025, at the Westfield Washington School Corporation Administration Building (19500 Tomlinson Rd, Westfield, IN 46074).
4. A new Pre-bid meeting will be held on 10.22.2025 at 11:00AM for this project at the WWS NMS Project Jobsite trailer. This is a non-mandatory pre-bid meeting, but all contractors and vendors are encouraged to attend. Contractors can ask questions to the CMC and the A-F Civil Engineer at this meeting and answers will be incorporated into a new Addendum. All Contractors are invited to perform a field walk to review the existing conditions of Centennial Road after the meeting.

## II. CHANGES TO THE PROJECT CONTRACT MANUAL

1. All contractors shall review the attached CSO and A&F Engineering Addendum #19 Dated 10.13.2024 and incorporate the changes made to the drawings and specifications into the respective bid item scope of bid.
2. All Bidders shall review the updated Section 00 01 15 List of Drawings.
3. Bid Item #32 CRR Contractors can refer to the Quantity Sheet that was supplied by A F Engineers, but the Contractors are responsible for their own quantity take-offs and estimate and bid quantities.
4. Bid Item #32 CCR Contractors shall review the changes made to the various drawings in this Addendum 19.

## III. DESIGN INFORMATION

1. CSO, and A&F Engineering Addendum #19 Dated 10.13.2025.

END OF SECTION

## ADDENDUM

ADDENDUM NO. 19

**RE: Westfield Middle School – West**

**Date: October 13, 2025**

**By: Jeff Hill, A&F Engineering Company**



This Addendum is issued in accordance with the provisions of “The General Conditions of the Contract for Construction,” Article 1, “Contract Documents” and becomes a part of the Contract Documents as provided therein. This Addendum includes:

Addendum Pages: **1-2**

Attached Documents: Quantities

Attached Drawing Sheets: 2, 36, 37, 38 of 48

### PART 1 – GENERAL INFORMATION

#### 1.1 Quantities

- A. See attached sheet to be used for bidding purposes. Quantities have been updated based on RFI/contractor questions about multi-purpose path pavement, aggregate and subgrade treatment. Quantities for earthwork have received minor updates including cross sections on Line ‘PR-B’.

### PART 2 – BIDDING REQUIREMENTS

#### 2.1 Not Used

### PART 3 – SPECIFICATIONS

#### 3.1 Not Used

### PART 4 – DRAWINGS

EXPERIENCE. REPUTATION. RELATIONSHIPS

A. Reissue attached sheet.

4.2 Sheet 36 – 38

A. Recalculated Earthwork

## **PART 5 – QUESTIONS AND ANSWERS**

5.1 Not Used

**END ADDENDUM NO. 19**

**WWS NEW MIDDLE SCHOOL WEST  
CENTENNIAL ROAD RECONSTRUCTION  
LIST OF DRAWINGS**

<b>DRAWINGS</b>			
<b>No.</b>	<b>Drawing Title</b>	<b>Drawing Date</b>	<b>Revisions</b>
1 of 48	COVER SHEET	8/11/2025	
2 of 48	INDEX AND GENERAL NOTES	10/13/2025	Addendum 19
3 of 48	TYPICAL SECTIONS	10/02/2025	Addendum 18
4 of 48	PLAT NO. 1	8/11/2025	
5 of 48	MAINTENANCE OF TRAFFIC	8/11/2025	
6 of 48	MAINTENANCE OF TRAFFIC	8/11/2025	
7 of 48	MAINTENANCE OF TRAFFIC	8/11/2025	
8 of 48	MAINTENANCE OF TRAFFIC	8/11/2025	
9 of 48	MAINTENANCE OF TRAFFIC	8/11/2025	
10 of 48	PLAN – LINE “PR-B” STA. 10+00.00 TO STA. 16+00.00	10/02/2025	Addendum 18
11 of 48	PROFILE – LINE “PR-B” STA. 10+00.00 TO STA. 16+00.00	8/11/2025	
12 of 48	PLAN – LINE “PR-B” 16+00.00 TO 22+00.00	10/02/2025	Addendum 18
13 of 48	PROFILE – LINE “PR-B” STA. 16+00.00 TO STA. 22+00.00	8/11/2025	
14 of 48	PLAN – LINE “PR-B” 22+00.00 TO 28+00.00	10/02/2025	Addendum 18
15 of 48	PROFILE – LINE “PR-B” STA. 22+00.00 TO STA. 25+38.59	8/11/2025	
16 of 48	PLAN – LINE “PR-A” STA. 62+00.00 TO STA. 68+00.00	10/02/2025	Addendum 18
17 of 48	PLAN – LINE “PR-A” STA. 68+00.00 TO STA. 74+00.00	10/02/2025	Addendum 18
18 of 48	CURB RAMP DETAILS	8/11/2025	
19 of 48	EROSION CONTROL DETAIL	8/11/2025	
20 of 48	EROSION CONTROL DETAIL	8/11/2025	
21 of 48	PAVEMENT MARKING DETAILS	8/11/2025	
22 of 48	SHEET SIGN & POST SUMMARY TABLE	8/11/2025	
23 of 48	PAVEMENT MARKINGS SUMMARY OF QUANTITIES	8/11/2025	
24 of 48	MISCELLANEOUS DETAIL	10/02/2025	Addendum 18
25 of 48	PAVEMENT QUANTITIES AND APPROACH TABLE	10/02/2025	Addendum 18

**WWS NEW MIDDLE SCHOOL WEST  
CENTENNIAL ROAD RECONSTRUCTION  
LIST OF DRAWINGS**

26 of 48	STRUCTURE DATA TABLE	8/11/2025	
27 of 48	CROSS SECTIONS LINE "PR-B"	10/02/2025	Addendum 18
28 of 48	CROSS SECTIONS LINE "PR-B"	10/02/2025	Addendum 18
29 of 48	CROSS SECTIONS LINE "PR-B"	10/02/2025	Addendum 18
30 of 48	CROSS SECTIONS LINE "PR-B"	10/02/2025	Addendum 18
31 of 48	CROSS SECTIONS LINE "PR-B"	10/02/2025	Addendum 18
32 of 48	CROSS SECTIONS LINE "PR-B"	10/02/2025	Addendum 18
33 of 48	CROSS SECTIONS LINE "PR-B"	10/02/2025	Addendum 18
34 of 48	CROSS SECTIONS LINE "PR-B"	10/02/2025	Addendum 18
35 of 48	CROSS SECTIONS LINE "PR-B"	10/02/2025	Addendum 18
36 of 48	CROSS SECTIONS LINE "PR-B"	10/13/2025	Addendum 19
37 of 48	CROSS SECTIONS LINE "PR-B"	10/13/2025	Addendum 19
38 of 48	CROSS SECTIONS LINE "PR-B"	10/13/2025	Addendum 19
39 of 48	CROSS SECTIONS LINE "PR-A"	10/02/2025	Addendum 18
40 of 48	CROSS SECTIONS LINE "PR-A"	10/02/2025	Addendum 18
41 of 48	CROSS SECTIONS LINE "PR-A"	10/02/2025	Addendum 18
42 of 48	CROSS SECTIONS LINE "PR-A"	10/02/2025	Addendum 18
43 of 48	CROSS SECTIONS LINE "PR-A"	10/02/2025	Addendum 18
44 of 48	CROSS SECTIONS LINE "PR-A"	10/02/2025	Addendum 18
45 of 48	CROSS SECTIONS LINE "PR-A"	10/02/2025	Addendum 18
46 of 48	CROSS SECTIONS LINE "PR-A"	10/02/2025	Addendum 18
47 of 48	CROSS SECTIONS LINE "PR-A"	10/02/2025	Addendum 18
48 of 48	CROSS SECTIONS LINE "PR-A"	10/02/2025	Addendum 18

**WWS NEW MIDDLE SCHOOL WEST  
CENTENNIAL ROAD RECONSTRUCTION  
LIST OF DRAWINGS**

**Drawings included for reference and coordination ONLY.:**

<b>DRAWINGS</b>			
<b>No.</b>	<b>Drawing Title</b>	<b>Drawing Date</b>	<b>Revisions</b>
10F12	Topographic Survey	8/18/2023	BP 03
20F12	Topographic Survey	8/18/2023	BP 03
30F12	Topographic Survey	8/18/2023	BP 03
40F12	Topographic Survey	8/18/2023	BP 03
50F12	Topographic Survey	8/18/2023	BP 03
60F12	Topographic Survey	8/18/2023	BP 03
70F12	Topographic Survey	8/18/2023	BP 03
80F12	Topographic Survey	8/18/2023	BP 03
90F12	Topographic Survey	8/18/2023	BP 03
100F12	Topographic Survey	8/18/2023	BP 03
110F12	Topographic Survey	8/18/2023	BP 03
120F12	Topographic Survey	8/18/2023	BP 03
C100	COVER SHEET	8/8/2025	ASI 26 - Trans Pipe Outlet
C101	EXISTING CONDITIONS & DEMOLITION PLAN	1/22/2025	ASI 09 - Civil TAC Updates
C102	EXISTING CONDITIONS & DEMOLITION PLAN	6/17/2024	BP 03
C250	Index and Typ	6/21/2024	BP 03
C251	PLAN "PR-A" STA. 00+00 TO STA. 5+80	1/22/2025	ASI 09 - Civil TAC Updates
C252	PROFILE "PR-A" STA. 00+00 TO STA. 05+80	1/22/2025	ASI 09 - Civil TAC Updates
C253	PLAN "PR-A" STA. 05+50 TO STA. 11+00	1/22/2025	ASI 09 - Civil TAC Updates
C254	PROFILE "PR-A" STA. 05+50 TO STA. 11+00	1/22/2025	ASI 09 - Civil TAC Updates
C255	PLAN "PR-A" STA. 11+00 TO STA. 15+39	1/22/2025	ASI 09 - Civil TAC Updates
C256	PROFILE "PR-A" STA. 11+00 TO STA. 15+39	1/22/2025	ASI 09 - Civil TAC Updates
C257	PLAN "PR-B" STA. 00+00 TO STA. 05+00	1/22/2025	ASI 09 - Civil TAC Updates
C258	PROFILE "PR-B" STA. 00+00 TO STA. 5+50	6/17/2024	BP 03

**WWS NEW MIDDLE SCHOOL WEST  
CENTENNIAL ROAD RECONSTRUCTION  
LIST OF DRAWINGS**

C259	PLAN "PR-B" STA. 05+00 TO STA. 07+91	1/22/2025	ASI 09 - Civil TAC Updates
C260	PROFILE "PR-B" STA. 05+50 TO STA. 7+91	6/17/2024	BP 03
C261	PLAN "PR-C" STA. 00+00 TO STA. 06+00	1/22/2025	ASI 09 - Civil TAC Updates
C262	PROFILE "PR-C" STA. 00+00 TO STA. 06+00	6/17/2024	BP 03
C263	PLAN "PR-C" STA. 06+00 TO STA. 12+00	1/22/2025	ASI 09 - Civil TAC Updates
C264	PROFILE "PR-C" STA. 06+00 TO STA. 12+00	6/17/2024	BP 03
C265	PLAN "PR-C" STA. 12+00 TO STA. 17+00	1/22/2025	ASI 09 - Civil TAC Updates
C266	PROFILE "PR-C" STA. 12+00 TO STA. 18+00	6/17/2024	BP 03
C267	PLAN "PR-C" STA. 17+00 TO STA. 23+00	1/22/2025	ASI 09 - Civil TAC Updates
C268	PROFILE "PR-C" STA. 18+00 TO STA. 24+00	6/17/2024	BP 03
C269	PLAN "PR-C" STA. 23+00 TO STA. 29+79	1/22/2025	ASI 09 - Civil TAC Updates
C270	PROFILE "PR-C" STA. 24+00 TO STA. 29+52	9/26/2024	ASI 02 - Civil Updates
C300	OVERALL GRADING PLAN	1/22/2025	ASI 09 - Civil TAC Updates
C301	GRADING PLAN	1/22/2025	ASI 09 - Civil TAC Updates
C302	GRADING PLAN	1/22/2025	ASI 09 - Civil TAC Updates
C303	GRADING PLAN	1/22/2025	ASI 09 - Civil TAC Updates
C304	GRADING PLAN	1/22/2025	ASI 09 - Civil TAC Updates
C305	GRADING PLAN	1/22/2025	ASI 09 - Civil TAC Updates
C306	GRADING PLAN	1/22/2025	ASI 09 - Civil TAC Updates
C307	GRADING PLAN	1/22/2025	ASI 09 - Civil TAC Updates
C401	SWPPP PLAN (INITIAL)	6/17/2024	BP 03
C402	SWPPP PLAN (INITIAL)	6/17/2024	BP 03
C403	SWPPP PLAN (CONST.)	1/22/2025	ASI 09 - Civil TAC Updates
C404	SWPPP PLAN (CONST.)	1/22/2025	ASI 09 - Civil TAC Updates
C405	SWPPP PLAN (FINAL)	1/22/2025	ASI 09 - Civil TAC Updates
C406	SWPPP PLAN (FINAL)	1/22/2025	ASI 09 - Civil TAC Updates



**WWS NEW MIDDLE SCHOOL WEST  
CENTENNIAL ROAD RECONSTRUCTION  
LIST OF DRAWINGS**

C407	SWPPP PLAN (DETAILS)	6/17/2024	BP 03
C408	SWPPP PLAN (DETAILS)	6/17/2024	BP 03
C409	SWPPP PLAN (INFORMATION)	6/21/2024	BP 03
C410	SWPPP PLAN (INFORMATION)	1/22/2025	ASI 09 - Civil TAC Updates
C500	STRUCTURE DATA TABLE	1/22/2025	ASI 09 - Civil TAC Updates
C500A	PIPE DATA TABLE	1/22/2025	ASI 09 - Civil TAC Updates
C501	UTILITY PLAN	2/28/2025	ASI 13 - Site Utility Modifications
C502	UTILITY PLAN	2/28/2025	ASI 13 - Site Utility Modifications
C503	UTILITY PLAN	2/28/2025	ASI 13 - Site Utility Modifications
C504	UTILITY PLAN	2/28/2025	ASI 13 - Site Utility Modifications
C505	UTILITY PLAN	1/22/2025	ASI 09 - Civil TAC Updates
C506	UTILITY PLAN	8/20/2025	ASI 26 - Trans Pipe Outlet
C601	SANITARY PLAN & PROFILE	2/28/2025	ASI 13 - Site Utility Modifications
C700	OVERALL UTILITY PLAN	1/22/2025	ASI 09 - Civil TAC Updates
C701	STORM PLAN & PROFILE	1/22/2025	ASI 09 - Civil TAC Updates
C702	STORM PLAN & PROFILE	1/22/2025	ASI 09 - Civil TAC Updates
C703	STORM PLAN & PROFILE	1/22/2025	ASI 09 - Civil TAC Updates
C704	STORM PLAN & PROFILE	2/28/2025	ASI 13 - Site Utility Modifications
C705	STORM PLAN & PROFILE	1/22/2025	ASI 09 - Civil TAC Updates
C706	STORM PLAN & PROFILE	1/22/2025	ASI 09 - Civil TAC Updates
C707	STORM PLAN & PROFILE	1/22/2025	ASI 09 - Civil TAC Updates
C708	STORM PLAN & PROFILE	1/22/2025	ASI 09 - Civil TAC Updates
C709	STORM PLAN & PROFILE	1/22/2025	ASI 09 - Civil TAC Updates

**WWS NEW MIDDLE SCHOOL WEST  
CENTENNIAL ROAD RECONSTRUCTION  
LIST OF DRAWINGS**

C710	STORM PLAN & PROFILE	1/22/2025	ASI 09 - Civil TAC Updates
C711	STORM PLAN & PROFILE	1/22/2025	ASI 09 - Civil TAC Updates
C712	STORM PLAN & PROFILE	1/22/2025	ASI 09 - Civil TAC Updates
C713	STORM PLAN & PROFILE	1/22/2025	ASI 09 - Civil TAC Updates
C901	SITE DETAILS	1/22/2025	ASI 09 - Civil TAC Updates
C902	SITE DETAILS	6/17/2024	BP 03
C903	SITE DETAILS	6/21/2024	BP 03
C904	SITE DETAILS	1/22/2025	ASI 09 - Civil TAC Updates
C905	SITE DETAILS	1/22/2025	ASI 09 - Civil TAC Updates
C906	SITE DETAILS	9/26/2024	ASI 02 - Civil Updates
C907	SITE DETAILS	2/28/2025	ASI 13 - Site Utility Modifications
L010	TREE PRESERVATION PLAN	12/6/2024	Conformed Set (12/06/2024)
L100	REFERENCE PLAN	12/6/2024	Conformed Set (12/06/2024)
L101	MATERIALS & NOTES	12/6/2024	Conformed Set (12/06/2024)
L102	MATERIALS & NOTES	12/6/2024	Conformed Set (12/06/2024)
L103	MATERIALS & NOTES	12/6/2024	Conformed Set (12/06/2024)
L104	MATERIALS & NOTES	12/6/2024	Conformed Set (12/06/2024)
L105	MATERIALS & NOTES	12/6/2024	Conformed Set (12/06/2024)
L106	MATERIALS & NOTES	12/6/2024	Conformed Set (12/06/2024)
L107	MATERIALS & NOTES	12/6/2024	Conformed Set (12/06/2024)
L108	MATERIALS & NOTES	12/6/2024	Conformed Set (12/06/2024)
L201	LAYOUT PLAN	12/6/2024	Conformed Set (12/06/2024)
L202	LAYOUT PLAN	12/6/2024	Conformed Set (12/06/2024)
L203	LAYOUT PLAN	12/6/2024	Conformed Set (12/06/2024)
L204	LAYOUT PLAN	12/6/2024	Conformed Set (12/06/2024)

**WWS NEW MIDDLE SCHOOL WEST  
CENTENNIAL ROAD RECONSTRUCTION  
LIST OF DRAWINGS**

L205	LAYOUT PLAN	12/6/2024	Conformed Set (12/06/2024)
L206	LAYOUT PLAN	12/6/2024	Conformed Set (12/06/2024)
L207	LAYOUT PLAN	12/6/2024	Conformed Set (12/06/2024)
L208	LAYOUT PLAN	12/6/2024	Conformed Set (12/06/2024)
L301	ENLARGED ATHLETIC PLANS	12/6/2024	Conformed Set (12/06/2024)
L302	ENLARGED ATHLETIC PLANS	12/6/2024	Conformed Set (12/06/2024)
L303	ENLARGED ATHLETIC PLANS	11/22/2024	ASI 04 - Irrigation Room Dugout
L304	ENLARGED ATHLETIC PLANS	12/6/2024	Conformed Set (12/06/2024)
L305	ENLARGED ATHLETIC PLANS	12/6/2024	Conformed Set (12/06/2024)
L306	ENLARGED ATHLETIC PLANS	12/6/2024	Conformed Set (12/06/2024)
L307	ENLARGED ATHLETIC PLANS	12/6/2024	Conformed Set (12/06/2024)
L308	BLEACHER AND PRESS BOX PLANS & DETAILS	12/6/2024	Conformed Set (12/06/2024)
L309	BLEACHER AND PRESS BOX PLANS & DETAILS	12/6/2024	Conformed Set (12/06/2024)
L310	BLEACHER AND PRESS BOX PLANS & DETAILS	12/6/2024	Conformed Set (12/06/2024)
L311	BLEACHER AND PRESS BOX PLANS & DETAILS	12/6/2024	Conformed Set (12/06/2024)
L312	BLEACHER AND PRESS BOX PLANS & DETAILS	12/6/2024	Conformed Set (12/06/2024)
L313	BLEACHER AND PRESS BOX PLANS & DETAILS	12/6/2024	Conformed Set (12/06/2024)
L314	BLEACHER AND PRESS BOX PLANS & DETAILS	12/6/2024	Conformed Set (12/06/2024)
L315	BLEACHER AND PRESS BOX PLANS & DETAILS	12/6/2024	Conformed Set (12/06/2024)
L316	BLEACHER AND PRESS BOX PLANS & DETAILS	12/6/2024	Conformed Set (12/06/2024)
L317	BLEACHER AND PRESS BOX PLANS & DETAILS	12/6/2024	Conformed Set (12/06/2024)
L318	BLEACHER AND PRESS BOX PLANS & DETAILS	12/6/2024	Conformed Set (12/06/2024)
L401	PLANTING PLAN	12/6/2024	Conformed Set (12/06/2024)
L402	PLANTING PLAN	12/6/2024	Conformed Set (12/06/2024)

**WWS NEW MIDDLE SCHOOL WEST  
CENTENNIAL ROAD RECONSTRUCTION  
LIST OF DRAWINGS**

L403	PLANTING PLAN	12/6/2024	Conformed Set (12/06/2024)
L404	PLANTING PLAN	7/26/2024	Conformed Set (12/06/2024)
L405	PLANTING PLAN	7/26/2024	Conformed Set (12/06/2024)
L406	PLANTING PLAN	7/26/2024	Conformed Set (12/06/2024)
L407	PLANTING PLAN	7/26/2024	Conformed Set (12/06/2024)
L408	PLANTING PLAN	7/26/2024	Conformed Set (12/06/2024)
L500	SITE DETAILS	12/6/2024	Conformed Set (12/06/2024)
L501	SITE DETAILS	12/6/2024	Conformed Set (12/06/2024)
L502	SITE DETAILS	12/6/2024	Conformed Set (12/06/2024)
L510	ATHLETIC DETAILS	12/6/2024	Conformed Set (12/06/2024)
L511	ATHLETIC DETAILS	12/6/2024	Conformed Set (12/06/2024)
L512	ATHLETIC DETAILS	12/6/2024	Conformed Set (12/06/2024)

**END OF SECTION**

**SECTION 00 11 13  
ADVERTISEMENT FOR BIDS**

SUMMARY

Notice is hereby given that SEALED BIDS will be received:

**BY AND AT: Hagerman, Inc.  
C/O Westfield Washington School Corporation Administration Building  
19500 Tomlinson Road  
Westfield, IN 46074  
Attn: Brian Kelly**

**FOR A NEW: Westfield Middle School West -  
Centennial Road Reconstruction  
17707 Centennial Road  
Westfield, IN 46074  
(New Project Address)**

**Until: 11:00 A.M., local time, Tuesday, November 4 , 2025**

**DESCRIPTION OF PROJECT:** New Centennial Road Reconstruction

(Note: The Project Bid Date Has Changed and the Project is Being Re-Advertised.)

**RECEIPT OF BIDS:** Bids received by mail or other carrier must be addressed to: Hagerman, Inc. c/o Brian Kelly, Westfield Washington School Corp. Administration Building, 19500 Tomlinson Rd., Westfield, IN 46074 and received on or before 11:00 A.M., Tuesday, November 4, 2025, to be valid. Bids received after the designated day and time listed above will be returned unopened. Any postal/courier service is the agent of the Bidder.

**BID OPENING:** Bids will be publicly opened and read aloud on Tuesday, November 4, 2025, at 11:00 A.M., local time, at Westfield Washington School Corp. Administration Building, 19500 Tomlinson Rd., Westfield, IN 46074.

**PRE-BID MEETING:** A pre-bid meeting for interested parties will be held on Wednesday, October 22, 2025, at 11:00 A.M., local time. The Meeting will be held at the Hagerman Inc On Site Jobsite Office Trailer, for the WWW NMSW Project, Located at 17707 Centennial Road, Westfield IN, 46074. (Note: The pre bid meeting is not mandatory, but bidders are encouraged to attend and visit the site before bidding.)

**CONTRACT TYPE:** The project(s) will be constructed utilizing the Construction Manager as Constructor (CMc) delivery method for public work. The Construction Manager will contract with multiple First Tier Subcontractors for the Bid items listed below, with bids received on a lump sum basis for each bid item. Each proposal shall include all labor, equipment, and materials necessary to complete the project in strict accordance with the Construction Drawings, Project Schedule, Project Contract Manual and Technical Specifications.

**SECTION 00 11 13  
ADVERTISEMENT FOR BIDS**

The Construction Manager will receive sealed Bids for the following Bid Items of work:

Bid Package #05 - Bid Item #32 Centennial Road Improvements Work

(Note: Bid Package 01 through Bid Package 04, Bid Item #01 through Bid Item #31 previously bid.)

**SUBCONTRACTOR PREQUALIFICATION:** All prospective bidders for the new Westfield Middle School West project are required to complete the Hagerman Inc. Corporate Prequalification process as condition before the subcontract award or the issuance of the subcontract agreement. This includes safety, experience, and financials. Directions and the link for prequalification can be found online at <https://www.thehagermangroup.com/contact>. Prequalification information is required to be updated annually to maintain an active prequalification status. If you have prequalification-specific questions, please email them to Chris Combs (Prequalification Manager) at CCombs@HagermanGC.com or call 317.577.6836. All prequalification documents must be submitted by subcontractors for this project by **11:00 A.M. October 21<sup>st</sup>, 2025**.

**Documents Prepared by:**

CSO Architects Inc.  
8831 Keystone Crossing  
Indianapolis, IN 46240

A&F Engineering  
8365 Keystone Crossing, Suite 201  
Indianapolis, IN 46240

**Construction Manager as Constructor (CMc)**

Hagerman, Inc.  
10315 Allisonville Road  
Fishers, IN 46038-2017

**BID DOCUMENTS:** Interested Prime Bidders may purchase Bidding Documents at Eastern Engineering. Documents will be available on or after September 15th, 2025. Documents are available electronically by contacting:

Mike Holtkamp, Hagerman, [MHoltkamp@Hagermangc.com](mailto:MHoltkamp@Hagermangc.com) or Cell: 317.627.2138  
Hagerman, Inc. Main Office (Fishers, IN): 317.577.6836

Michael Uhrig, Hagerman, [MUhrig@Hagermangc.com](mailto:MUhrig@Hagermangc.com) or Cell: 317.317.4937  
Hagerman, Inc. Main Office (Fishers, IN): 317.577.6836

**SECTION 00 11 13**  
**ADVERTISEMENT FOR BIDS**

Documents will also be available from Eastern Engineering  
<http://distribution.easternengineering.com/View/Default.aspx>  
Contact at Eastern Engineering is:

Henry Clayton  
Email: [Henry.Clayton@easternengineering.com](mailto:Henry.Clayton@easternengineering.com) or Office: (317) 598-0661

Any questions concerning bidding this project, project completion, scheduling, project administration, etc. shall be directed to:

Mike Holtkamp, Hagerman, Inc., [MHoltkamp@Hagermangc.com](mailto:MHoltkamp@Hagermangc.com) or Cell 317.627.2138  
Hagerman, Inc. Main Office (Fishers, IN): Cell Phone 317.627.2138

Michael Uhrig, Hagerman, [MUhrig@Hagermangc.com](mailto:MUhrig@Hagermangc.com) or Cell: 317.617.4937  
Hagerman, Inc. Main Office (Fishers, IN): 317.577.6836

**BID DOCUMENTS - REVIEW:** Construction will be in accordance with the bid documents, which may be viewed at the following locations, as well as local plan rooms:

1. Hagerman, Inc  
10315 Allisonville Road  
Fishers, IN 46038  
317-577-6836
2. CSO Architects Inc.  
8831 Keystone Crossing  
Indianapolis, IN 26240
3. Eastern Engineering  
9901 Allisonville Road  
Fishers, IN 46038

**BID SECURITY:** Bidders are required to submit a Bid Security in the form of a Bid Bond in the amount of 10% of the Base Bid or certified check in the amount of 10% of the Base Bid made payable to Hagerman, Inc.

**BID DOCUMENTS TO BE SUBMITTED:** Bidders are to submit one (1) hard copy of the following bid form, and other documents enclosed in a sealed envelope addressed to Hagerman, Inc. C/O Westfield Washington School Corporation:

1. One (1) copy of Hagerman Bid Form.
2. One (1) copy of Bid Security in the form of an AIA A310 Bid Bond in the amount of 10% of the Base Bid or a certified check in the amount of 10% of the Base Bid.  
Note: The Bid Bond and/or Certified check made payable to Hagerman, Inc.

**SECTION 00 11 13**  
**ADVERTISEMENT FOR BIDS**

3. One (1) copy of the Indiana State Board of Accounts Form 96 (revised 2013) including a signed Non-Collusion Affidavit.
4. Bid Submittal Checklist

**PERFORMANCE BOND AND PAYMENT BOND:** A Performance Bond and Payment Bond in the amount of one hundred percent (100%) of the Contract Amount may be required of the successful bidder. Bidders will provide a cost for this bond on the bid form.

**NOTE:** The Subcontractor Material and Supplier List will be due within 24 hours after the receipt of Bid.

**E-VERIFY AND BACKGROUND CHECKS:** The Contractor and subcontractors shall fully comply with all the E-Verify requirements set forth in Ind. Code 22-5-1.7. <https://www.uscis.gov/e-verify> and background checks.

**SAFETY:** All Contractors shall comply with OSHA and IOSHA rules and regulations regarding Safety for this project and All contractors shall abide by the 2020 Hagerman Safety manual. The safety manual can be found accessible at [www.thehagermangroup.com](http://www.thehagermangroup.com) using password "safety."

**TAXES, PERMITS, INSPECTIONS:** All Bids shall be submitted without inclusion in the bid price for the amounts, if any, of Indiana State Gross Retail and Use Tax (generally called the "Sales Tax") for materials and properties that are to be purchased by the Bidder that will become a permanent part of the Project. The Owner will provide a tax-exempt form.

END OF SECTION



**SECTION 00 21 13**  
**INSTRUCTIONS TO BIDDERS**

The following information and special instructions are being furnished to prospective Bidders desiring to submit Bids for the Work on the following project.

**1.01 PROJECT INFORMATION**

New Westfield Middle School West

This package is for the construction of the new Westfield Middle School West located at 17707 Centennial Road, Westfield, IN 46074.

Bids will be received for the following Bid Item:

Bid Package #05, Bid Item #32 – Centennial Road Improvements Work

(Note: Bid Package #01, #02, #03, & #04 and Bid Items #01 through #31 previously bid)

**1.02 BID DOCUMENTS**

1. The bidding documents include the following:
  - a. Project Contract Manual and Project Technical Specifications covering Divisions 00 through 33.
  - b. Contract Documents per specification section 00 01 15.
2. Procurement: Bid documents will be available on or after September 15th, 2025, Subcontractors can receive drawings/specifications, and addenda by contacting Michael Uhrig by email at [MUhrig@hagermangc.com](mailto:MUhrig@hagermangc.com) or by phone at (317) 617-4937.
3. Documents will also be available from Eastern Engineering  
<http://distribution.easternengineering.com/View/Default.aspx>  
Contact at Eastern Engineering is: Londa Munn  
Email: [Londa.Munn@easternengineering.com](mailto:Londa.Munn@easternengineering.com) / Office: (317) 598-0661
4. Any questions concerning bidding this project, project completion, scheduling, project administration, bidder questions, etc shall be directed to:

Mike Holtkamp, Hagerman, [mholtkamp@hagermangc.com](mailto:mholtkamp@hagermangc.com) or Cell: 317.627.2138  
Hagerman, Inc. Main Office (Fishers, IN): 317.577.6836

Michael Uhrig, Hagerman, [MUhrig@Hagermangc.com](mailto:MUhrig@Hagermangc.com) or Cell: 317.617.4937  
Hagerman, Inc. Main Office (Fishers, IN): 317.577.6836

**SECTION 00 21 13**  
**INSTRUCTIONS TO BIDDERS**

5. Bid Document Review: Construction will be in accordance with the bid documents, which may be viewed at the following locations, as well as local plan rooms:

Hagerman, Inc  
10315 Allisonville Road  
Fishers, IN 46038

CSO Architects, Inc.  
8831 Keystone Crossing  
Indianapolis, IN 46240

Eastern Engineering  
9901 Allisonville Road  
Fishers, IN 46038

1.03 INSTRUCTIONS TO BIDDERS

1. Refer to Section 00 24 00 – “Scope of Bids” for a breakdown of Bid Item(s).
2. Bid Delivery: Deliver all sealed Bids by 11:00 A.M., Tuesday, November 04, 2025:

Westfield Washington School Corporation  
Administration Building  
19500 Tomlinson Road  
Westfield, IN 46074  
Attn: Mr. Brian Kelly

**3. Faxed, emailed, or electronic bids will not be accepted.**

1. Bids submitted on the bid opening date will be received up to the hour of 11:00 A.M. Bids will be opened in public and read aloud at the Westfield Washington School Corporation Administration Building, 19500 Tomlinson Road, Westfield, IN 46074 on Thursday, November 4, 2025, at 11:00 A.M. by the Owner.
2. Bidder shall submit one (1) hard copy of the following bid documents enclosed in a sealed envelope addressed to Hagerman, Inc. C/O Westfield Washington School Corporation:
  - a. One (1) copy of Hagerman Bid Form
  - b. One (1) copy of Bid Security in the form of an AIA A310 Bid Bond in the amount of 10% of the Base Bid or a certified check in the amount of 10% of the Base Bid. Note: Make Bid Bond and/or Certified check payable to Hagerman, Inc.

**SECTION 00 21 13**  
**INSTRUCTIONS TO BIDDERS**

- c. One (1) copy of the Indiana State Board of Accounts Form 96 (revised 2013) including a signed Non-Collusion Affidavit
  - d. Bid Submittal Checklist
3. Mark the front of the envelope as follows:
- Include the Bidder's name, address, and telephone number on the outside of the envelope.
  - Include the Construction Manager's name, address, and main point of contact on the outside of the envelope.
  - Include the notation "BID ENCLOSED" on the outside of the envelope.
  - Include the project name on the outside of the envelope.
  - Indicate the bid items you are bidding on the outside of the envelope.
4. Hand delivered bids will be accepted. Bids may be hand delivered to the Westfield Washington School Corporation Administration Building at the address identified above. Hand delivered bids shall be enclosed in a sealed opaque envelope and shall include all required bid documents and forms.

**1.04 EXAMINING THE SITE**

1. The Bidder shall carefully study and compare the Bid Documents with each other and with other work being bid concurrently or presently under construction to the extent that it relates to the Work for which the Bid is submitted, shall examine the site and local conditions, and shall at once report to the Construction Manager errors, inconsistencies or ambiguities discovered.
2. Each Bidder submitting a Bid represents that he/she has read and understands the Bidding Documents and Scope of Work. Each Bidder represents that he/she has visited the site and has adequately familiarized himself/herself with the existing conditions. No additional cost to the Owner will be allowed by the Subcontractor's failure to avail himself/herself of a complete and thorough on-site inspection of existing conditions.
3. Arrangements to visit and examine the site in accordance with the General Instructions to Bidders may be made by contacting Hagerman, Inc., **Mike Holtkamp** Cell: **(317) 627-2138**. Questions during the bidding period shall be in written form **ONLY** and should be directed to Mike Holtkamp, [mholtkamp@hagermangc.com](mailto:mholtkamp@hagermangc.com)

**SECTION 00 21 13**  
**INSTRUCTIONS TO BIDDERS**

**1.05 PRE-BID CONFERENCE**

1. A pre-bid meeting for all parties interested in bidding the project will be held Wednesday, October 22, 2025, at 11:00 A.M., local time. The Meeting will be held at the Westfield Washington Schools New Middle School West Jobsite trailer, 17707 Centennial Rd, Westfield, IN 46074. Representatives of the Owner, Construction Manager, and the Architect/Engineer will be present to answer questions regarding the project and bidding procedures. All interested Bidders are encouraged to attend.

**1.06 GENERAL INSTRUCTIONS**

1. Each Bid shall have the amount clearly and legibly written in ink or typed on the prepared Bid Form.
2. Bids shall include whole numbers only, no cents will be accepted.
3. Bids shall not be withdrawn for a period of ninety (90) calendar days after the receipt of Bids, without the consent of the Owner and Construction Manager.
4. Bid Alternates shall be good for a period of one hundred eighty (120) calendar days after receipt of Bids, without the consent of the Owner and Construction Manager.
5. The Construction Manager / Owner reserves the right to reject any and all Bids and waive any informality in the bidding.
6. Bidders shall also be prepared to submit a Bid Breakdown including, but not limited to, labor, materials, Sub-subcontractors, overhead, profit, etc. if/when required.
7. Taxes, Permits, and Inspections:
  - a. Indiana State Gross Retail and Use Tax: All Bids shall be submitted without inclusion in the bid price for the amounts, if any, of Gross Retail and Use Tax (generally called the "Sales Tax").
  - b. Permits: See Specification Section 00 24 00 – Scopes of Bid for which permits will be provided by the Owner / Construction Manager and which shall be included in the Subcontractor's scope of work and pricing.
  - c. Construction Schedule: Each entity submitting a Bid, unless exception is taken in writing, indicates it can and will have its own worker, Subcontractors, materials, and equipment available to keep its Work on or ahead of the Preliminary Construction Schedule. Refer Section 00 31 13 Preliminary Schedule for further schedule requirements.

**1.07 SUBCONTRACTOR MATERIAL / SUPPLIER LIST**

**SECTION 00 21 13**  
**INSTRUCTIONS TO BIDDERS**

1. The Subcontractor Material and Supplier List will be due within 24 hours after the receipt of the Bid.

**1.08 SUBSTITUTIONS**

It shall be the Bidder's responsibility to meet the listed requirements if he intends to utilize any of the Acceptable Manufacturers in lieu of the Reference Standard.

1. The description or naming of materials, products and equipment in the bidding documents is done for the purpose of establishing the Reference Standard of required function, dimension, appearance, and quality, and not for the purpose of limiting competition.

- a. Refer to Section 00 43 25, Substitution Request Form, for form to be used to request substitutions and approvals.

**1.09 E-VERIFY**

1. The Contractor and subcontractors shall fully comply with all the E-Verify requirements set forth in Ind. Code 22-5-1.7. <https://www.uscis.gov/e-verify>

**1.10 SAFETY**

1. Safety: All Contractors shall comply with OSHA and IOSHA rules and regulations regarding Safety for this project and All contractors shall abide by the 2020 Hagerman Safety manual. The safety manual can be found accessible at [www.thehagermangroup.com](http://www.thehagermangroup.com) using password "safety."

**1.11 TAXES, PERMITS, INSPECTIONS**

1. Taxes, Permits, Inspections: All Bids shall be submitted without inclusion in the bid price for the amounts, if any, of Indiana State Gross Retail and Use Tax (generally called the "Sales Tax") for materials and properties that are to be purchased by the Bidder that will become a permanent part of the Project. Owner will provide a tax-exempt form.

END OF SECTION

**SECTION 00 41 16  
BID FORM**

COMPANY NAME OF BIDDER: \_\_\_\_\_

**PROJECT: Westfield Middle School West Centennial Road Improvements**

**REVISED BID DATE: November 4, 2025**

**BID TIME: 11:00 A.M.**

**BIDDERS ARE TO COMPLETE AND SUBMIT THE FOLLOWING FORMS WITH THEIR BID:**

1. Hagerman Bid Form One (1) Hard Copy
2. Bid Security one (1) hard copy, either in the form of an AIA A310 Bid Bond in the amount of 10% of the Base Bid or a certified check in the amount of 10% of the Base Bid. Note: Make Bid Bond or certified check payable to Hagerman, Inc.  
Note: Make Bid Bond and/or Certified check payable to Hagerman, Inc.
3. Indiana State Board of Accounts Form 96 (revised 2013) including a signed Non-Collusion Affidavit
4. Bid Submittal Checklist
5. Documents listed above in a sealed envelope.

**SUBMIT SEALED BIDS TO:**

Hagerman Inc.  
C/O Westfield Washington School Corporation  
19500 Tomlinson Road  
Westfield, IN 46074  
Attn: Mr. Brian Kelly

The undersigned Bidder, having visited the site of the work and having familiarized himself/herself with local conditions affecting the cost of this Work, hereby proposes to perform the following listed Work, in accordance with the Project Contract/Subcontract Manual/Specifications and Drawings, dated 8/11/2025 and all Addenda and Revisions/Clarifications Letters issued prior to the due date of bids, for a **Lump Sum Amount**.

Guarantee of Prices: By signing and submitting a proposal, Bidder agrees to guarantee the bids (prices) for ninety (90) calendar days from the date of submittal and to enter into an agreement with the Hagerman Inc. to perform work for the stated bid sums at any time during this period. Further, the Bidder agrees to guarantee Alternate Bid Sums for those Alternate Bids not initially acceptable in the Notice of Award or Agreement for an additional one hundred eighty (120) calendar days from the date of Notice of Award.

**SECTION 00 41 16  
BID FORM**

Addenda Received & Included: No. 18 Dated 10.07.2025

Addenda Received & Included: No. 19 Dated 10.13.2025

Addenda Received & Included: No. \_\_\_\_\_ Dated \_\_\_\_\_

Addenda Received & Included: No. \_\_\_\_\_ Dated \_\_\_\_\_

Addenda Received & Included: No. \_\_\_\_\_ Dated \_\_\_\_\_

Addenda Received & Included: No. \_\_\_\_\_ Dated \_\_\_\_\_

Revisions/Clarifications Letter Received/Included: Dated \_\_\_\_\_

Revisions/Clarifications Letter Received/Included: Dated \_\_\_\_\_

**PROJECT SCHEDULE ACKNOWLEDGEMENT:** I certify that I have reviewed the project schedule included in Specification Section 00 31 13, covered by this Bid Form, and acknowledge that the price stated below includes all costs to achieve the schedule without any modifications. \_\_\_\_\_ (initial)

**SCOPE OF BIDS ACKNOWLEDGEMENT:** I certify that I have reviewed the Scope of Bids included in Specification Section 00 24 00, covered by this Bid Form, and acknowledge that the price stated below includes all costs associated with the work stated in the Scope of Bids without any modifications. \_\_\_\_\_ (initial)

NOTE: Refer to Section 00 43 21 for Allowance(s).

**PERFORMANCE BOND AND PAYMENT BOND:** A Performance Bond and Payment Bond in the amount of one hundred percent (100%) of the Contract Amount may be required of the successful bidder. Provide amount on bid form with associated Bid Item.

**NOTE:** The Subcontractor, Material and Supplier List will be due within 24 hours of receipt of the Bid.  
**BASE BIDS (Whole Numbers Only):**

**SECTION 00 41 16  
BID FORM**

**Bid Package #05, Bid Item #32 – Centennial Road Reconstruction Work:**

(words) \_\_\_\_\_

\_\_\_\_\_

\_\_\_\_\_ \$ \_\_\_\_\_

Performance & Payment Bond (add) \$ \_\_\_\_\_

**ALLOWANCES:** Allowances, if any, shall be used by the Bidder to pay the Cost of the Work per Construction Manager’s written direction. Allowances are firm for the life of the project. Any unused Allowances shall be returned upon the final accounting of the Work. Note: Your Base bid should include all associated overhead and profit markups for this contract allowance and this contract allowance is pure cost of the work. **The allowance(s) shall be included in the total lump sum bid amount.**

1. Bid Item #32 Centennial Road Reconstruction Contractor shall include One (1) Fifty Thousand Dollar Allowance, \$50,000, to be used as directed by the Construction Manager.



**SECTION 00 41 16  
BID FORM**

**GENERAL INFORMATION:**

**LEGAL NAME OF BIDDER:** \_\_\_\_\_

**d/b/a NAME (if different):** \_\_\_\_\_

**ADDRESS:** \_\_\_\_\_

\_\_\_\_\_

\_\_\_\_\_

**FEDERAL ID NUMBER:** \_\_\_\_\_

**PHONE (Office):** \_\_\_\_\_

**PHONE (Mobile):** \_\_\_\_\_

**FAX:** \_\_\_\_\_

**E-MAIL ADDRESS:** \_\_\_\_\_

**BY:** \_\_\_\_\_

**PRINTED NAME:** \_\_\_\_\_

**TITLE:** \_\_\_\_\_

**DATE:** \_\_\_\_\_

**Please provide the contact information for the project estimator responsible for preparing this bid, and proposed staff that would be assigned to this project, as well as a resume for each person.**

**ESTIMATOR NAME:** \_\_\_\_\_

**EMAIL & CELL PHONE NUMBER:** \_\_\_\_\_

**PROJECT MANAGER NAME:** \_\_\_\_\_

**EMAIL & CELL PHONE NUMBER:** \_\_\_\_\_

**SITE FOREMAN/SUPERINTENDENT:** \_\_\_\_\_

**EMAIL & CELL PHONE NUMBER:** \_\_\_\_\_

**SECTION 00 41 16**  
**BID FORM**  
**END OF SECTION**

**00 41 16-5**

**BID FORM**  
**ADDENDUM 19**  
**10/13/2025**

Item No.	Description	Unit	Quantity
1	MOBILIZATION AND DEMOBILIZATION	LS	1.0
2	CONSTRUCTION ENGINEERING	LS	1.0
3	CLEARING OF RIGHT OF WAY	LS	1.0
4	EXCAVATION, COMMON	CYS	1,184.0
5	BORROW	CYS	3,876.0
6	STORM WATER MANAGEMENT BUDGET	LS	1.0
7	STORMWATER MANAGEMENT IMPLEMENTATION	LS	1.0
8	SWQCP PREPARATION	LS	1.0
9	SUBGRADE TREATMENT, TYPE IBC	SYS	8,731.1
10	COMPACTED AGGREGATE, NO. 53, BASE	CYS	3,261.9
11	SUBGRADE TREATMENT, TYPE IBL	SYS	2,109.0
12	CURB AND GUTTER, CONCRETE	LFT	262.2
13	CURB RAMP, CONCRETE	SYS	48.2
14	DETECTABLE WARNING SURFACES	SYS	7.1
15	ASPHALT FOR TACK COAT	TON	6.7
16	HMA SURFACE, TYPE B, 9.5 MM	TON	721.0
17	HMA INTERMEDIATE, TYPE B, 19.0 MM	TON	1,127.0
18	HMA BASE, TYPE B, 25.0 MM	TON	2,905.0
19	HMA SURFACE, TYPE B, 12.5 MM	TON	350.0
20	MULCHING MATERIAL	TON	2.8
21	FERTILIZER	TON	0.6
22	SEED MIXTURE, T	LBS	207.9
23	SEED MIXTURE, U	LBS	207.9
24	PIPE, TYPE 2, CIRCULAR, 12 IN.	LFT	133.0
25	PIPE, TYPE 2, CIRCULAR, 15 IN.	LFT	40.0
26	INLET, TYPE E7	EACH	2.0
27	PIPE END SECTION, DIAMETER 12 IN.	EACH	2.0
28	15" PIPE CATCH BASIN	EACH	2.0
29	STRUCTURE, REINFORCED CONCRETE, BOX SECTIONS, 5 FT X 2 FT, WITH WINGWALLS	LFT	85.0
29	GRATED CASTING AND RISER RINGS	EACH	1.0
30	STRUCTURE BACKFILL, TYPE 1	CYS	25.7
31	FLOWABLE BACKFILL, REMOVABLE	CYS	48.4
32	COMPACTED AGGREGATE, NO. 8	CYS	34.6
33	CASTING, FURNISH AND ADJUST TO GRADE	EACH	1.0
34	RIPRAP, REVETMENT	TON	39.0
35	GEOTEXTILES FOR RIPRAP, TYPE 1B	SYS	52.0
36	MAINTAINING TRAFFIC	LS	1.0
37	CONSTRUCTION SIGN, TYPE A	EACH	8.0
38	BARRICADE, TYPE III-A	LFT	84.0
39	ROAD CLOSURE SIGN ASSEMBLY	EACH	3
40	DETOUR ROUTE MARKER ASSEMBLY	EACH	48
41	TEMPORARY PAVEMENT MARKING, REMOVABLE, 4 IN.	LFT	4,732
42	SIGN, SHEET, WITH LEGEND, 0.080 IN. THICKNESS	SFT	55
43	SIGN, SHEET, WITH LEGEND, 0.100 IN. THICKNESS	SFT	13.8
44	SIGN POST, SQUARE, TYPE 2, REINFORCED ANCHOR BASE	LFT	131.8
45	SOLAR POWERED FLASHING BEACON ASSEMBLY	EACH	2.0
46	TRAFFIC SIGNAL HEAD, NO. 1 SECTION, 12 IN. AMBER	EACH	2.0
47	LINE, THERMOPLASTIC, SOLID, WHITE, 4 IN.	LFT	4,177.0
48	LINE, THERMOPLASTIC, SOLID, YELLOW, 4 IN.	LFT	3,006.0
49	PAVEMENT MESSAGE MARKING, THERMOPLASTIC, LANE INDICATION ARROW	EACH	9.0
50	TRANSVERSE MARKING, THERMOPLASTIC, STOP LINE, 24 IN.	LFT	36.0

UTILITIES

UTILITY	OWNER	ADDRESS
Gas	Citizen's Energy Group	Rich Miller 317-927-4684 rmiller@citizensenergygroup.com 2150 Dr. Martin Luther King Jr. Street Indianapolis, IN 46202
Sanitary	Citizen's Energy Group	David Clark 317-429-3993 dclark@citizensenergygroup.com 2150 Dr. Martin Luther King Jr. Street Indianapolis, IN 46202
Water	Citizen's Energy Group	Scott Ritter 317-927-4434 sritter@citizensenergygroup.com 2150 Dr. Martin Luther King Jr. Street Indianapolis, IN 46202
Electric	Duke Energy Group	Frank Hancock 765-524-7945 frank.hancock@duke-energy.com 4535 Jane Blvd New Castle, IN 47362
Communications	Comcast	BSM Groups LLC 812-271-2400 comcastrelocate@bsmgroups.com 1600 West Fountain Dr Bloomington, IN 47404
	Crown Castle Fiber	Craig Brown 317-819-8648 craig.brown@crowncastle.com 800 Oliver Ave. Suite 1 Indianapolis, IN 46225
	Duke Fiber	Charlotte Seegrist 513-287-1105 DukeFiberMW@Duke-Energy.com 139 E. 4th Street Cincinnati, OH 45202
	Frontier Communication	Dan Koch 260-415-9328 daniel.koch@ftr.com 4027 Beckwith Drive Fort Wayne, IN 46808
	Metronet	Doug Reckart 317-809-8067 doug.reckart@metronet.com 8036 Cole Wood Blvd. Indianapolis, IN 46239
	Spectrum Communications	Byron Posey 317-538-2016 byron.posey@charter.com 3030 Roosevelt Ave Indianapolis, IN 46218
	Verizon/MCI	Rolland Craig 317-498-1242 dennis.craig@verizon.com 6835 Hillsdale Ct. Indianapolis, IN 46250
	Zayo Group	Waylon Higgins 765-341-1199 waylon.higgins@zayo.com 9209 Castlegate Dr Indianapolis, IN 46256

GENERAL NOTES

**	All Earth Shoulders, median areas, and cut and fill slopes shall be plain or mulched seeded except where sodding is specified.
**	Clearing and removal of woody vegetation will be kept to a minimum between construction limits and right-of-way.
**	Tack Coat shall be placed on new and existing bituminous before a new lift of bituminous is added.
**	City of Westfield Construction Standards and Specifications: <a href="https://www.westfieldin.gov/DocumentCenter/View/366/Standards-PDF">https://www.westfieldin.gov/DocumentCenter/View/366/Standards-PDF</a>
**	2026 INDOT Standard Specifications: <a href="https://www.in.gov/dot/div/contracts/standards/book/sep25/sep.htm">https://www.in.gov/dot/div/contracts/standards/book/sep25/sep.htm</a>
**	Represents General Notes required.

INDEX

SHEET NO.	SHEET DESIGNATION
1	Title
2	Index and General Notes
3	Typical Sections
4	Plat No. 1
5-9	Traffic Maintenance Details
10-17	Plan and Profile
18	Curb Ramp Details
19-20	Erosion Control Details
21	Pavement Markings
22	Pavement Markings Summary of Quantities Table
23	Sheet Sign & Post Summary Table
24	Miscellaneous Details
25	Approach Table
26	Structure Data Table
27-48	Cross Sections

REVISIONS

SHEET NO.	DATE	REVISED
3	10/02/2025	Updated shoulder width, Updated legend
10	10/02/2025	Updated Str. 11A, Added detail notes to box culvert and casting
12	10/02/2025	Added "Attach to Pipe By Others" note to Str. 16, Removed extra pavement line, updated legend
14	10/02/2025	Added "Attach to Pipe By Others" note to Str. 17, updated legend
16	10/02/2025	Removed (C1) notes, updated legend
24	10/02/2025	Added Box Culvert Details
27-48	10/02/2025	Recalculated Earthwork
36-38	10/13/2025	Recalculated Estimated Earthwork

R/W INDEX

SHEET NO.	DESIGNATION



VERIFICATION NOTE

Contractor shall verify all dimensions and clearances and all existing filed conditions before starting construction. Commencement of work constitutes acceptance of conditions.

Should different conditions be encountered, contact the engineer or designer before proceeding with work.

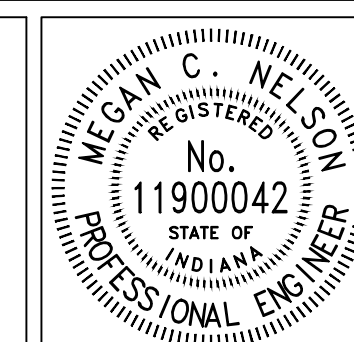

RECOMMENDED FOR APPROVAL	<i>Megan C. Nelson</i> DESIGN ENGINEER	08/11/2025 DATE
DESIGNED:	MCN	DRAWN:
		AJG
CHECKED:	JAH	CHECKED:
		JAH

WESTFIELD WASHINGTON SCHOOLS

INDEX AND GENERAL NOTES

HORIZONTAL SCALE	BRIDGE FILE
N/A	N/A
VERTICAL SCALE	DESIGNATION
N/A	--
SHEETS	
2	of 48
CONTRACT	
--	

Z:\2024\240787-CONTEXT DESIGN-TRAFFIC SIGNAL, SR 32-CENTENNIAL RD PH5 1.DWG\CENTENNIAL PLAN SET\240787-TTL CENTENNIAL.DWG

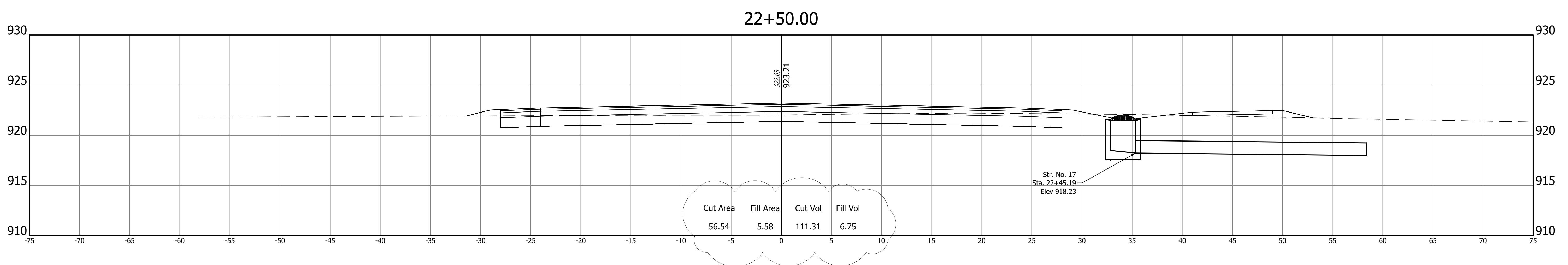
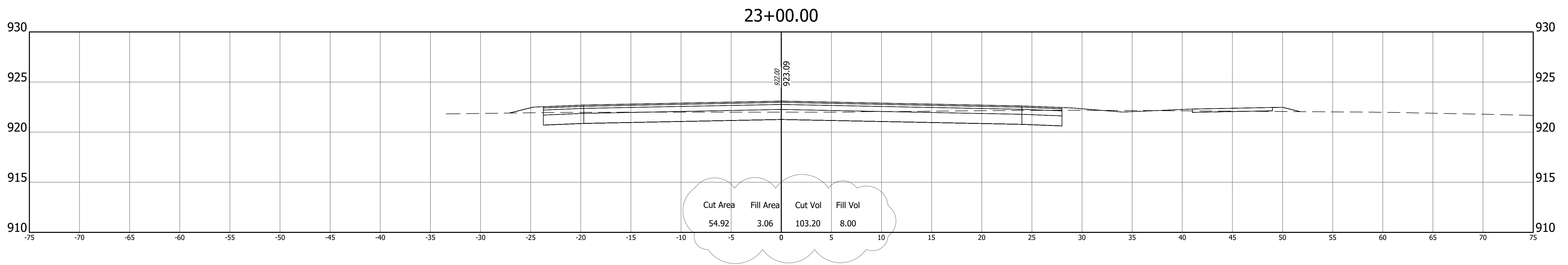
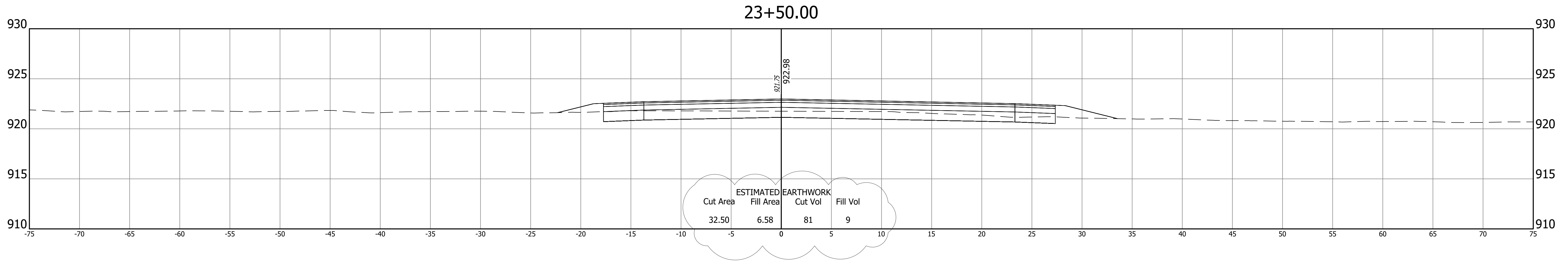

Z:\2024\240787-CONTEXT DESIGN TRAFFIC SIGNAL SR 32-CENTENNIAL RD PH5 1\DWG\CENTENNIAL PLAN SET\240787-CORRIDOR CENTENNIAL.DWG

REVISIONS	
DATE	ITEM
Oct 2, 2025	Updated Earthwork
Oct 13, 2025	Updated Estimated Earthwork

**A&F ENGINEERING**

Transportation & Site Engineering

Creating Order Since 1966

8365 Keystone Crossing, Suite 201, Indianapolis, IN. 46240 (317) 202-0864

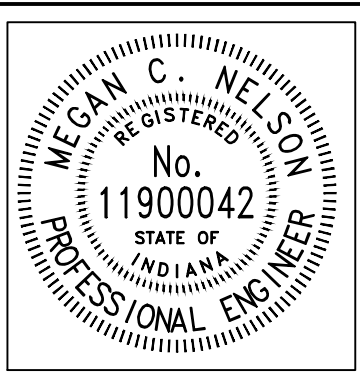

RECOMMENDED FOR APPROVAL	<i>Megan C. Nelson</i>	DESIGN ENGINEER	DATE
DESIGNED:	MCN	DRAWN:	AJG
CHECKED:	JAH	CHECKED:	JAH

**WESTFIELD WASHINGTON SCHOOLS**

**CROSS SECTIONS LINE "PR-B"**

HORIZONTAL SCALE	BRIDGE FILE
1"=5'	N/A
VERTICAL SCALE	DESIGNATION
1"=5'	--
SHEETS	
36	of 48
CONTRACT	
--	

Z:\2024\240787-CONTEXT DESIGN TRAFFIC SIGNAL SR 32-CENTENNIAL RD PH5 1.DWG\CENTENNIAL PLAN SET\240787-CORRIDOR CENTENNIAL.DWG

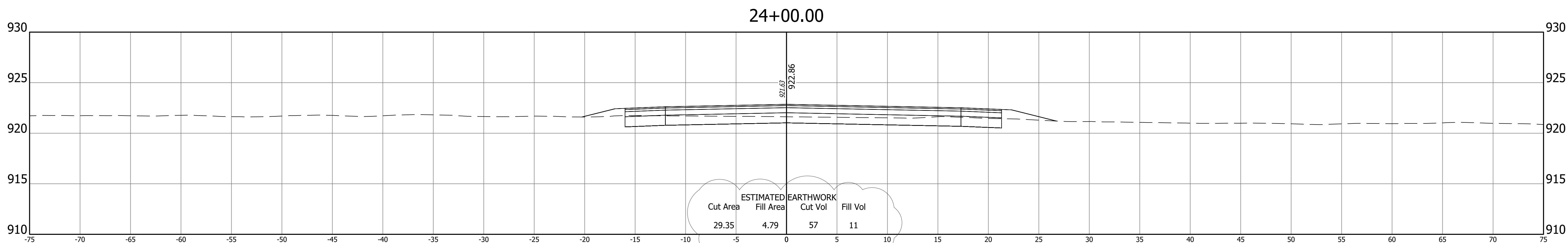
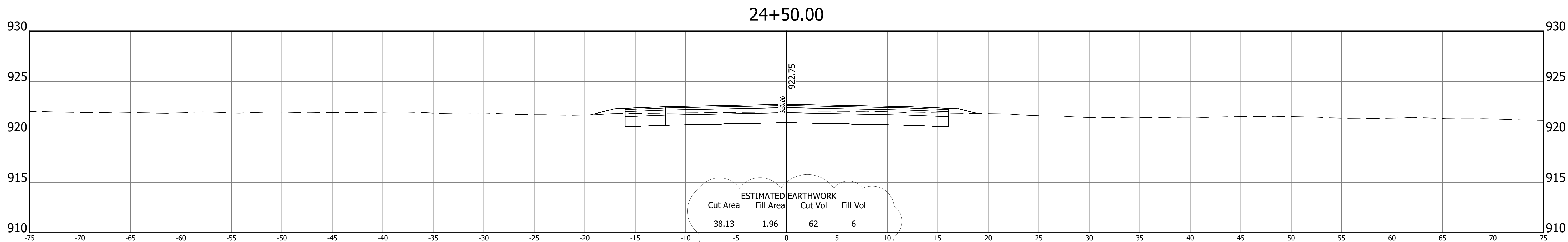
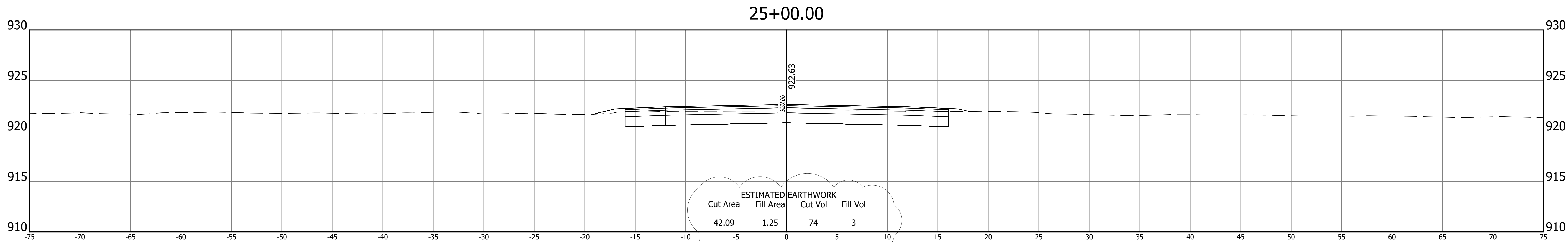

REVISIONS	
DATE	ITEM
Oct 2, 2025	Updated Earthwork
Oct 13, 2025	Updated Estimated Earthwork

**A&F ENGINEERING**

Transportation & Site Engineering

Creating Order Since 1966

8365 Keystone Crossing, Suite 201, Indianapolis, IN. 46240 (317) 202-0864

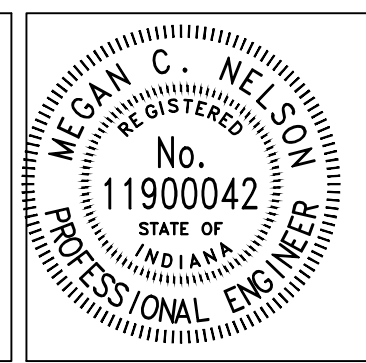

RECOMMENDED FOR APPROVAL	<i>Megan C. Nelson</i>	DESIGN ENGINEER	DATE
DESIGNED:	MCN	DRAWN:	AJG
CHECKED:	JAH	CHECKED:	JAH

**WESTFIELD WASHINGTON SCHOOLS**

**CROSS SECTIONS LINE "PR-B"**

HORIZONTAL SCALE	BRIDGE FILE
1"=5'	N/A
VERTICAL SCALE	DESIGNATION
1"=5'	--
SHEETS	
37 of 48	
CONTRACT	
--	

Z:\2025\240787-CONTEXT DESIGN TRAFFIC SIGNAL SR 32-CENTENNIAL RD PH5 1.DWG\CENTENNIAL PLAN SET\240787-CORRIDOR CENTENNIAL.DWG

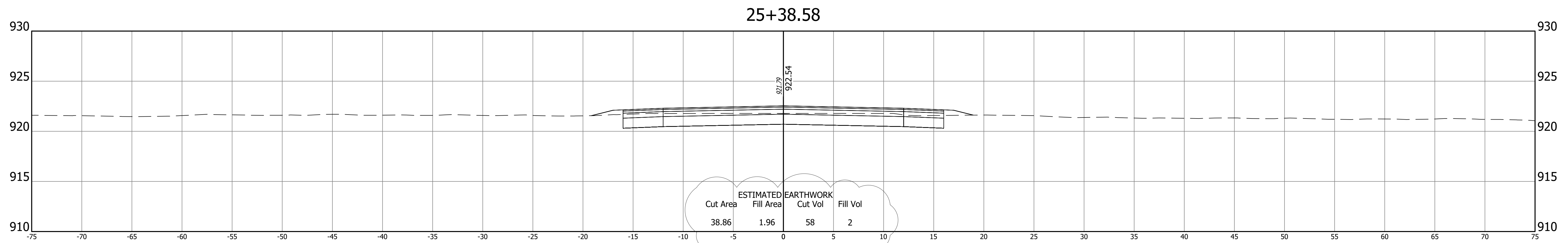

REVISIONS	
DATE	ITEM
Oct 2, 2025	Updated Earthwork
Oct 13, 2025	Updated Estimated Earthwork



**A&F ENGINEERING**  
 Transportation & Site Engineering  
 Creating Order Since 1966  
 8365 Keystone Crossing, Suite 201, Indianapolis, IN. 46240 (317) 202-0864

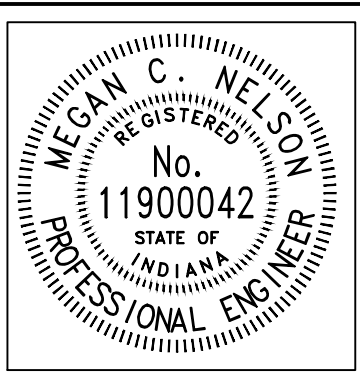

RECOMMENDED FOR APPROVAL	<i>Megan C. Nelson</i>	DESIGN ENGINEER	08/11/2025	DATE
DESIGNED:	MCN	DRAWN:	AJG	
CHECKED:	JAH	CHECKED:	JAH	

WESTFIELD WASHINGTON SCHOOLS

CROSS SECTIONS LINE "PR-B"

HORIZONTAL SCALE	BRIDGE FILE
1"=5'	N/A
VERTICAL SCALE	DESIGNATION
1"=5'	--
SHEETS	
38	of 48
CONTRACT	
--	